

GlueX FOB Assembly Sequence

Feb 2018

J. Bessuille

Assembly Sequence

Part 1: At Bates

1. Assemble Mirror box outside FOB
2. Mount Window to Box
3. Install water fittings, BarBox blankoffs, perform leak test / level sensor check
4. Install Mirrors into box (Plastic guide rails to be designed)
5. Test fit PMTs
6. Run light-tightness tests
7. Remove PMTs for shipping
8. Ship box with mirrors and window installed (dry)

Part 2: At JLab

1. Use Faro arm or Laser Tracker to fiducialize mirrors w.r.t. outside of box.
2. Install full array of PMTs on bench
3. Electronics test and laser calibration
4. Remove PMTs again (this time risers can be left on the box)
5. Lift box onto frame and affix, remove lifting eyes
6. Install hard stop and gaskets onto bar boxes
7. Use guide rails on DIRC frame to slide BBs into FOB, using hard stop as guide
8. Install clamping bracket to seal BB to FOB
9. Re-install PMTs and fill box with water.

2.7 Install hard stop and gaskets onto bar boxes

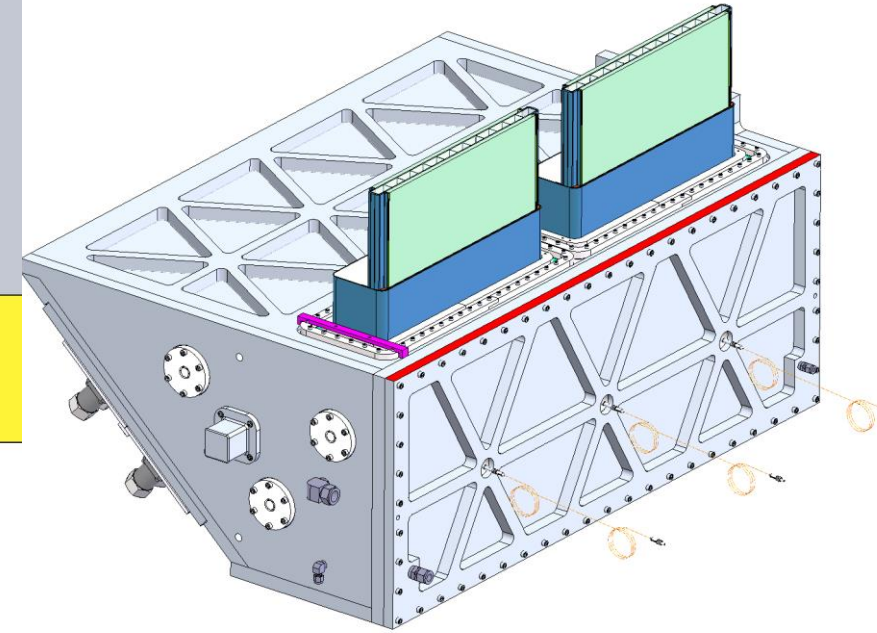
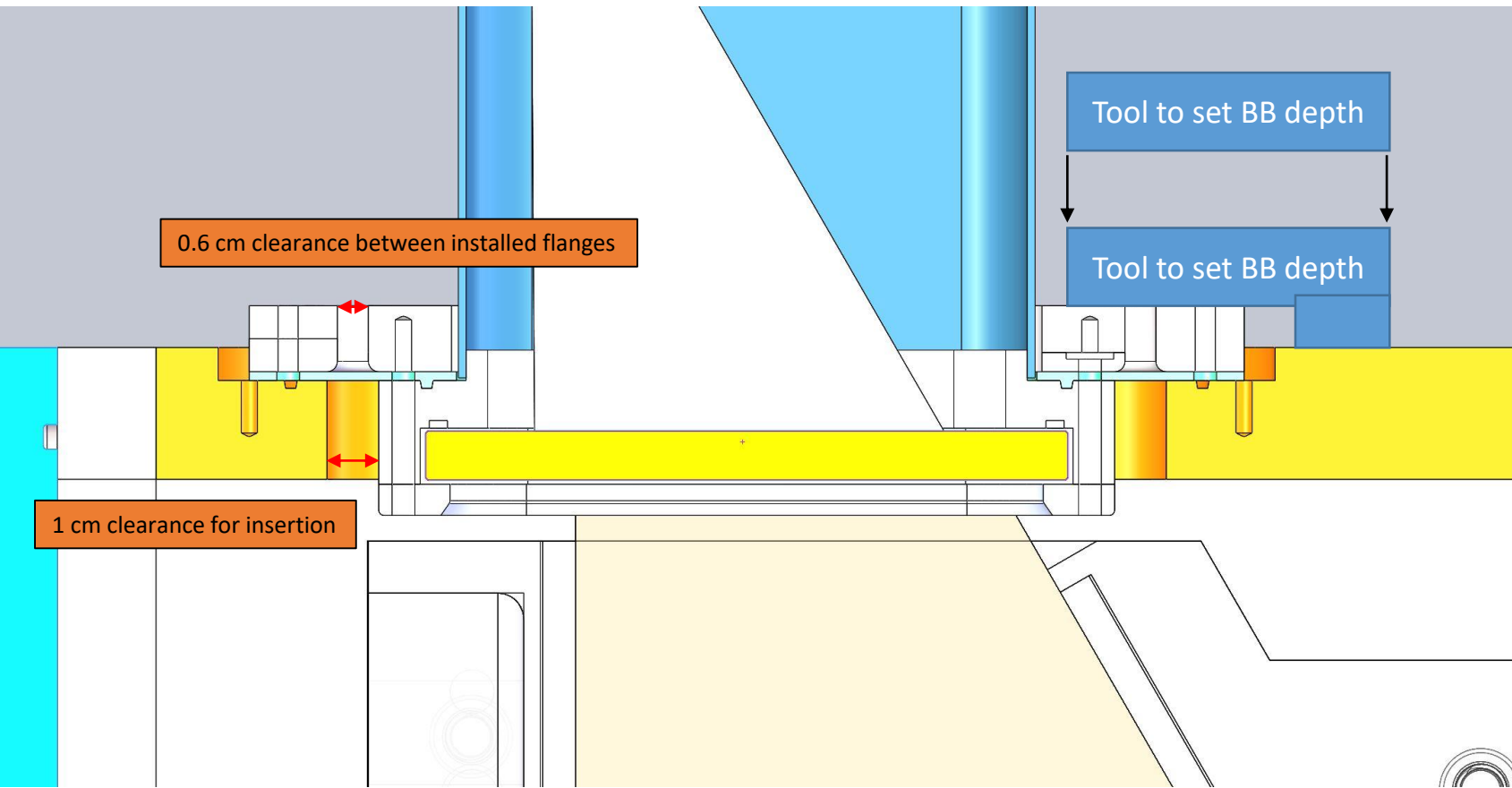

New PMT Bracket

