

REVISION HISTORY				
ZONE	REV	DESCRIPTION	DATE	APPROVED

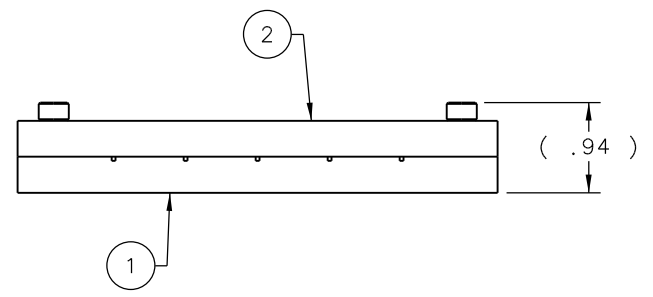
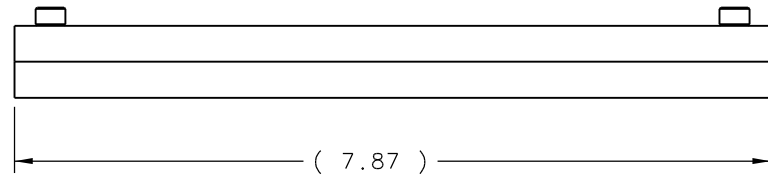
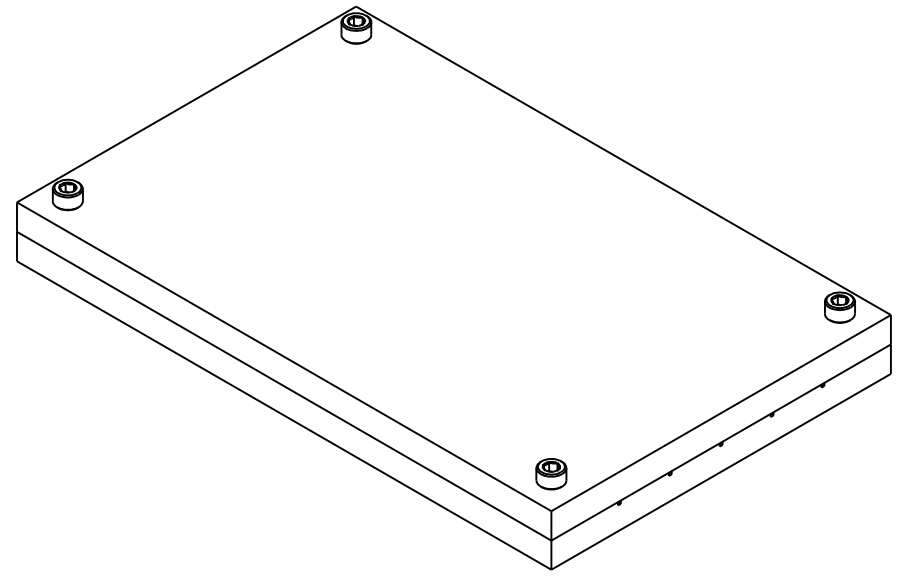
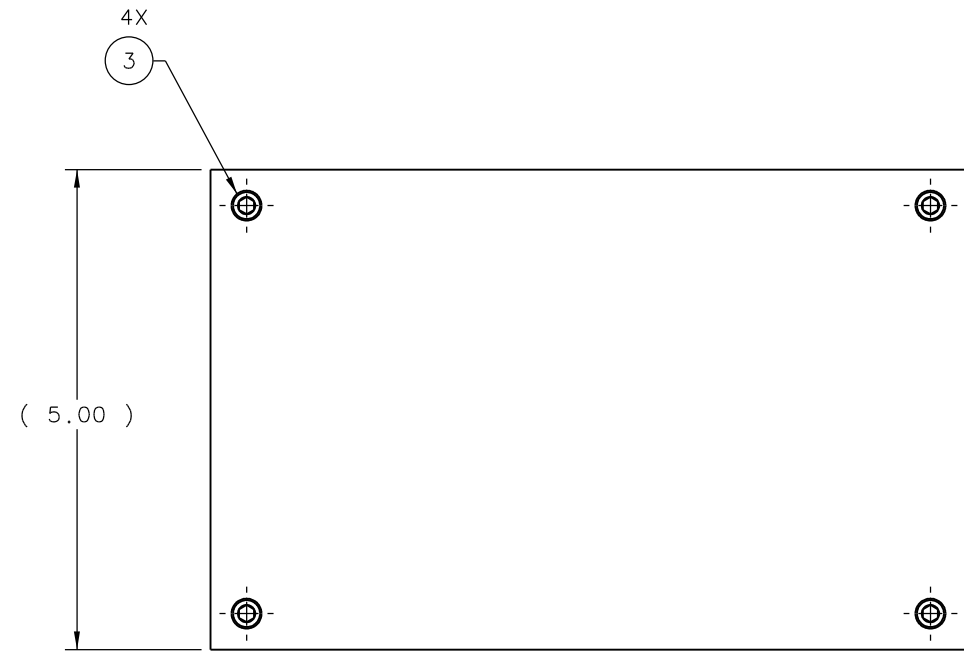

NOTES:

- SUGGESTED SOURCES OR JLAB APPROVED ALTERNATE:
 MCMaster-CARR
 (630) 833-0300
 www.mcmaster.com

QTY REQD	ITEM NO.	PART OR IDENTIFYING NO.	NOMENCLATURE OR DESCRIPTION	MATERIAL SPECIFICATION	NOTES
4	3	MCMaster-CARR #90128A945	SHCS, #10-32 X .75 LG	STEEL	1
1	2	D00000-15-00-2048	WLS 5 GROOVE STRAIGHTENER TOP		
1	1	D00000-15-00-2047	WLS 5 GROOVE STRAIGHTENER BASE		

DOCUMENT CONTROL STAMP

MATERIAL
SEE PARTS LIST

FINISH
MACHINED SURFACES
DEBURR & BREAK ALL SHARP EDGES

DO NOT SCALE DRAWING

DIM & TOL PER ASME Y14.5
UNLESS OTHERWISE SPECIFIED
DIMENSIONS ARE IN INCHES
TOLERANCES ARE:
FRACTIONS DECIMAL ANGLES
± N/A .X ± .1 .XX ± .01 .XXX ± .005

THIRD ANGLE PROJECTION

TRACKING NO.
N/A

APPROVALS
DRAWN C L HUTTON
CHECKED
APPROVED
APPROVED

DATE
22JAN13

United States Department of Energy

 Newport News Virginia

HALL D - GLUEX SPECTROMETER PAIR SPECTROMETER WLS 5 GROOVE STRAIGHTENING ASSY

SIZE DWG. NO. D D00000-15-00-1012 REV. -

SCALE 1:1 USED ON ASSY NO. SHEET 1 OF 1